

L-150
Lever Type
Load Binder

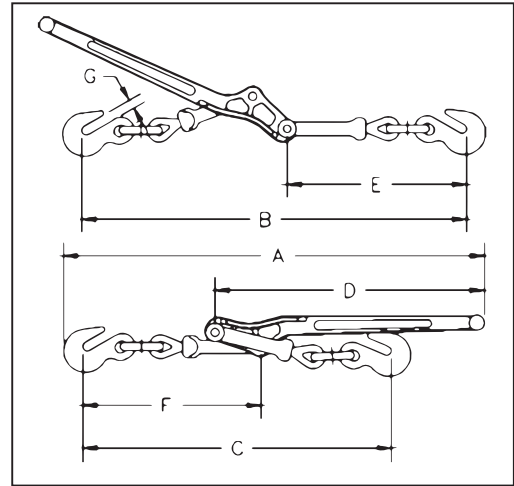

- Extra heavy construction at leverage point to prevent spreading. Heel of binder toggles away from load, permitting easy release.
- Ball and socket swivel joints at hook assemblies permit a straight line pull.
- Binders shown with Proof Loads have been individually proof tested to values shown, prior to shipment.
- Meets or exceeds requirements of US DOT FMCSA Part 393 Subpart I.

Load Rated®



L-150 Standard Lever Type Load Binders

Model	Stock No.	Std. Pkg.	Min-Max Chain Size (in)	Working Load Limit (lb)	Proof Load (lb)	Ultimate Load (lb)	Weight Each (lb)	Handle Length (in)	Take Up (in)	Dimensions (in)						
										A	B	C	D	E	F	G
7-1	1048128	4	5/16-3/8	5400	10800	19000	7.02	16.00	4.50	24.13	22.13	17.88	16.00	10.38	10.38	.50
A-1	1048146	4	3/8-1/2	9200	18400	33000	12.47	18.69	4.50	28.75	25.75	21.25	18.69	12.31	12.38	.63
C-1	1048164	4	1/2-5/8	13000	26000	46000	19.68	21.00	4.75	31.25	29.75	25.00	21.00	14.63	13.75	.72