

Lebus® Load Binders

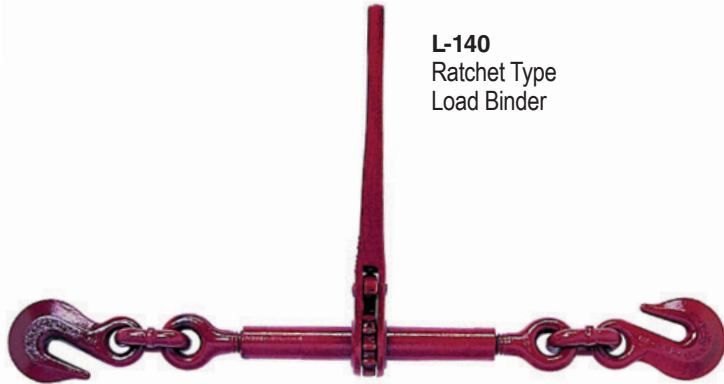

L-140
Ratchet Type
Load Binder

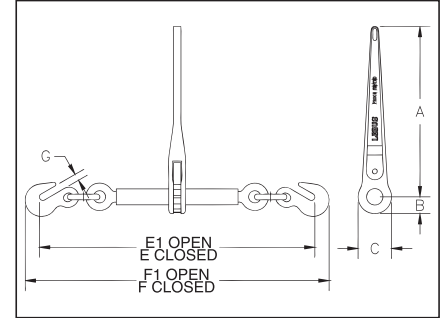

- Upgraded for use with Grades 70, 80 and 100 Chain.
- Utilizes standard Crosby A-323 Alloy Eye Grab Hooks.
- New design “one piece” forged handle.
- Continuous take-up feature provides finite adjustment to tie down load.
- One piece assembly, no bolts or nuts to loosen.
- Ratchet spring is rust proofed.
- All load bearing or holding parts forged.
- Easy operating positive ratchet.
- Binders shown with Proof Loads have been individually proof tested to values shown, prior to shipment.
- Meets or exceeds requirements of US DOT FMCSA Part 393 Subpart I.



Load Rated

L-140 Standard Ratchet Type Load Binders (Meets or exceeds requirements of US DOT FMCSA Part 393 Subpart I.)

Model	Stock No.	Min-Max Chain Size (in)	Working Load Limit (lb)*	Proof Load (lb)	Weight Each (lb)	Handle Length (in)	Barrel Length (in)	Take Up (in)	Dimensions (in)							
									A	B	C	E	E1	F	F1	G
R-7 **	1048404	5/16-3/8	8800	17600	12.11	14	10	8.0	14.00	1.38	2.75	22.94	30.94	25.13	33.13	.50
R-A **	1048422	3/8-1/2	15000	30000	14.70	14	10	8.0	14.00	1.38	2.75	25.25	33.25	27.63	35.63	.63
R-C ***	1048440	1/2-5/8	16000	32000	14.55	14	10	8.0	14.00	1.38	2.75	26.38	34.38	29.44	37.44	.72

* Ultimate Load is 3 times the Working Load Limit. ** Matches the Working Load Limit of Grade 100 chain for both sizes. *** Matches the Working Load Limit of Grade 100 chain for 1/2" size.

Chain & Accessories